

Critical Chain

Critical Chain Project Management (CCPM) was first publicised in 1997 in Eliyahu M. Goldratt's book, *Critical Chain*. It is a method of planning and managing projects that puts the main emphasis on the resources required to execute project tasks. It is based on methods and algorithms derived from the Theory of Constraints.

The critical chain is the sequence of both precedence- and resource-dependent terminal elements (activities) that prevents a project from being completed in a shorter time, given finite resources. If resources are always available in unlimited quantities, then a project's critical chain is identical to its critical path. The main features that distinguish the critical chain from the critical path are:

- The use of (often implicit) resource dependencies. Implicit means that they are not included in the project network but have to be identified by looking at the resource requirements.
- Lack of search for an optimum solution. This means that a 'good enough' solution is enough because:
 - As far as is known, there is no analytical method of finding an absolute optimum (i.e. having the overall shortest critical chain).
 - The inherent uncertainty in estimates is much greater than the difference between the optimum and near-optimum ("good enough" solutions).
- The identification and insertion of buffers:
 - project buffer
 - feeding buffers
 - resource buffers.
- Monitoring project progress and health by monitoring the consumption rate of the buffers rather than individual task performance to schedule.

Methodology

CCPM - Planning

A project plan is created in much the same fashion as with a traditional CPM¹ network. The plan is worked backward from a completion date with each task starting as late as possible. Two durations are entered for each task: a 'best guess' or 50% probability duration (an aggressive estimate), and a 'safe' duration, which should have higher probability of completion (perhaps 80%, 90% or even 95%, depending on the amount of risk that the organization can accept). The easy way to get this data is to ask two questions for each activity from the participating resource².

- How long would you take to perform this activity based on your previous experience (safe estimate)?
- How quickly could you perform this activity if everything goes well and you had all the inputs you needed at the start (aggressive estimate)?

Resources are then assigned to each task, and the plan is resource levelled using the 50% estimates. The longest sequence of resource-levelled tasks that lead from beginning to end of the project is then identified as the critical chain. The justification for using the aggressive estimates is that half of the tasks will finish early and half will finish late, so that the variance over the course of the project should be zero. All tasks are

¹ CPM = Critical Path Method, the traditional network scheduling methodology using single time estimates and usually drawn as a 'Precedence Diagram'.

² For more on durations see The Cost of Time - or who's duration is it anyway?:
http://www.mosaicprojects.com.au/Resources_Papers_009.html



scheduled as late as possible based on the resource requirements; ie, resource levelling is done on the ‘back pass’ and activities moved forward in time to eliminate overloads.

Recognizing that tasks are likely to take more time rather than less due to Parkinson's law³, Student syndrome⁴, or other reasons, ‘buffers’ are used to establish dates for deliverables and for monitoring project performance. The ‘extra’ duration of each task on the critical chain (the difference between the ‘safe’ durations and the aggressive durations) is gathered together in a buffer at the end of the project. In the same way, buffers are also gathered at the end of each sequence of tasks that feed into the critical chain. The most common approach to sizing buffers for a particular chain of tasks is to start with the 2-point range estimates outlined above, and use half of the difference between the sum of the longer "safe" estimates and of the shorter "aggressive but achievable" estimates.

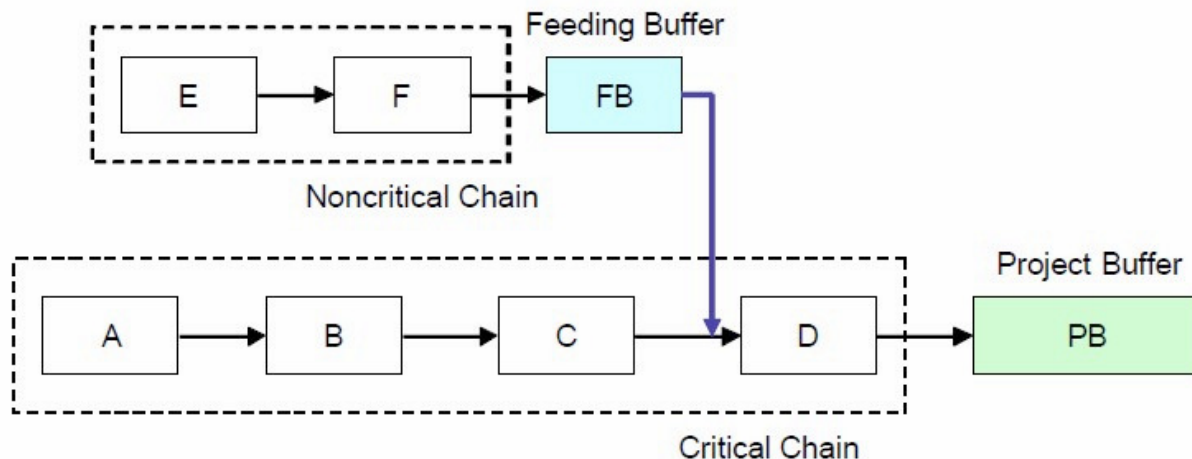

Finally, a baseline is established, which enables financial monitoring of the project.

CCPM - Execution

When the plan is complete and the project ready to kick off, the project network is fixed and the buffers size is ‘locked’ (i.e. their planned duration may not be altered during the project).

With no padding in the duration of individual tasks, the resources on the critical chain are required to work on the critical chain task and nothing else; multitasking is eliminated. And, because task durations have been planned at the aggressive duration, there is pressure on the resources to complete critical chain tasks as quickly as possible.

CCPM – Monitoring

Critical chain project management uses buffer management to assess the performance of the project. Because individual tasks will vary in duration from the aggressive estimate, there is no point in trying to force every task to complete ‘on time’; estimates can never be that perfect. Instead, the buffers that were created during the planning stage are monitored. Buffers are used to absorb any ‘wins’ and ‘losses’ - the effect of a task completing early being added into the buffer and delays deducted.

If the rate of buffer consumption is low, the project is on target. If the rate of consumption is such that there is likely to be little or no buffer at the end of the project, then corrective actions or recovery plans must be developed to recover the loss.

³ Parkinson's Law (Parkinson 1957); the work expands to fill the time available for its completion.

⁴ When students are given assignments, they usually start work at the last moment.

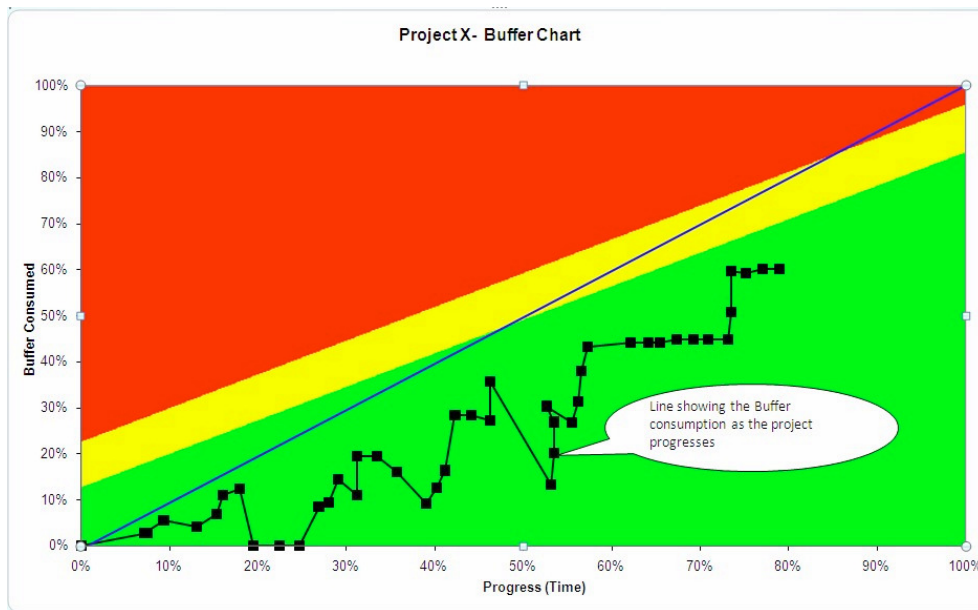

Key Differences between CCPM and CPM

The differences between CCPM and traditional ‘Critical Path’ (CPM) scheduling when it is implemented properly are not as great as many Critical Chain advocates would suggest. The practical differences are as follows:

- A typical CPM schedule has task estimates with a degree of ‘safety’ built in⁵. The expected times are longer than the 50% option used in CCPM. A typical Critical Path⁶ schedule may look like this:

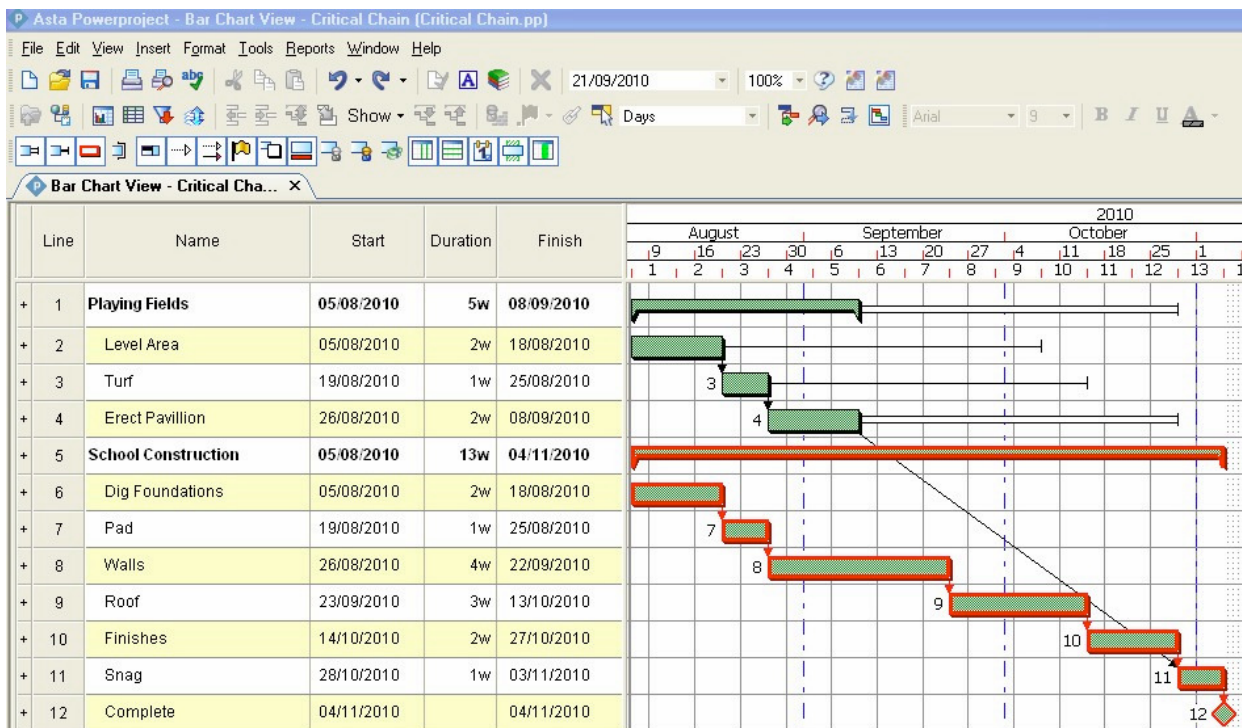

⁵ For more on duration estimating see: http://www.mosaicprojects.com.au/WhitePapers/WP1052_Time_Estimating.pdf

⁶ Schedules produced by Asta Powerproject: www.astadev.com

- The difference between the 'safe' and 50% estimates are identified for each activity.

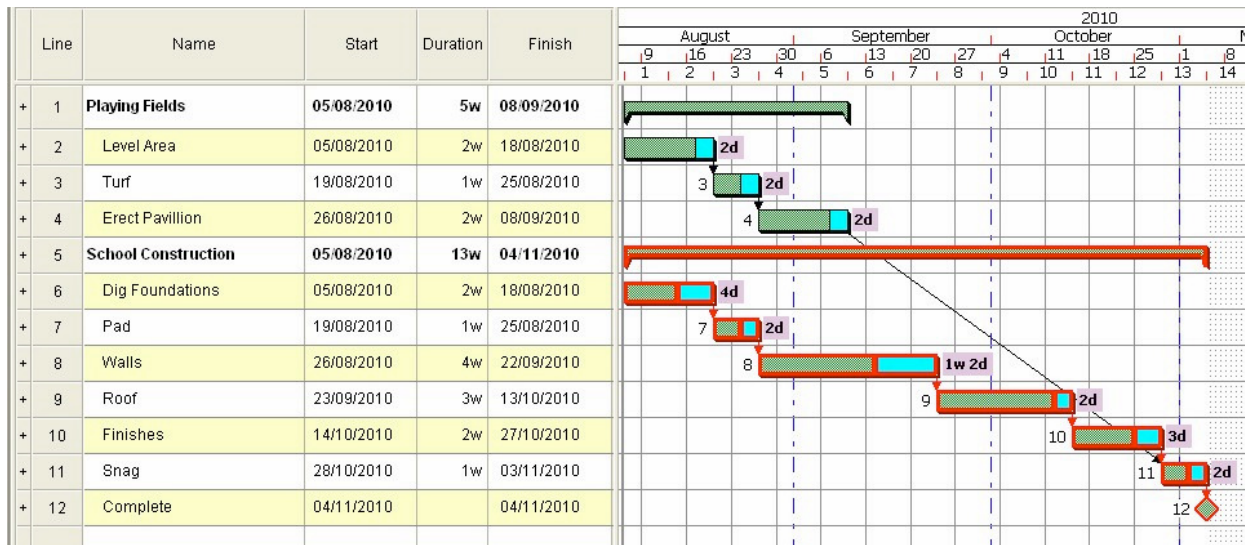

- These 'differences' are accumulated in buffers and all of the activities scheduled as late as possible based on resource availabilities.

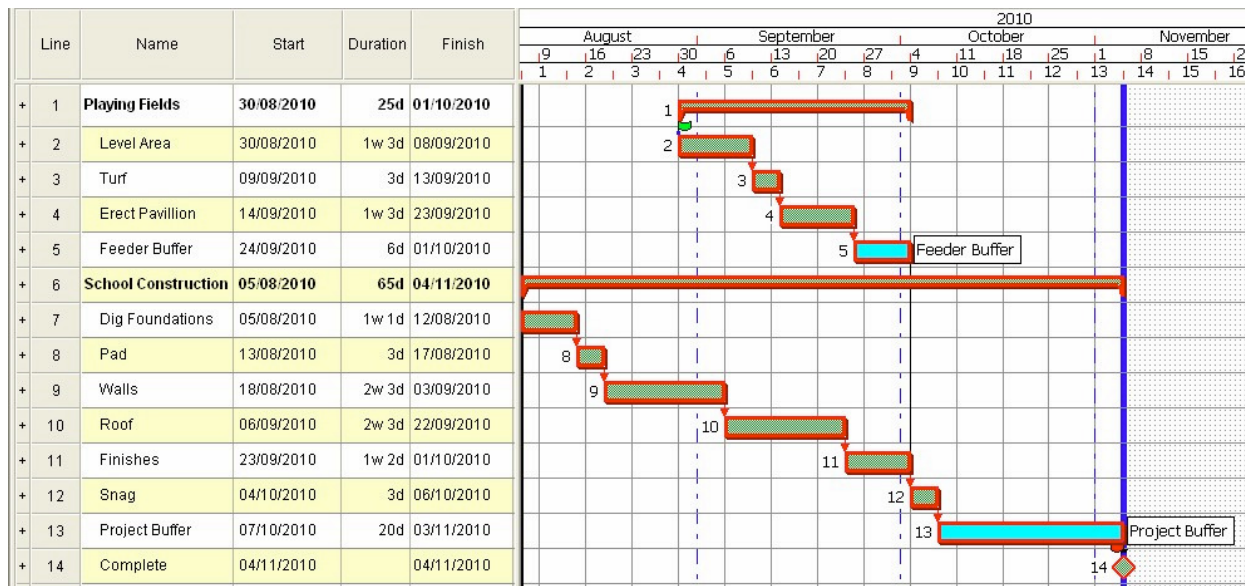

- Rather than monitoring individual task performance and re-scheduling to define slippage, the buffers are adjusted to maintain the project completion dates and the rate of buffer consumption is monitored.

Summary

The advantages of CCPM are not as great as many advocates would suggest, most comparisons are between very poorly managed environments and the improved situation once CCPM has been introduced⁷. However, CCPM does highlight a range of factors that are valuable in designing schedule management systems for any project or PMO:

⁷ It is likely similar improvements can be obtained using traditional CPM scheduling if applied with the same rigour as CCPM. See **A Guide to Scheduling Good Practice** for more on good scheduling practice: http://www.mosaicprojects.com.au/PDF/Good_Scheduling_Practice.pdf



- Senior management support is critical
- Multi-tasking is highly detrimental to performance
- Efficient use of resources is the key to project success
- Focusing on schedule performance is critical⁸
- People will change their expectations and performance if they understand the schedule and know it matters!⁹

An increasing range of scheduling tools, including Asta Powerproject, have ‘Critical chain’ capabilities built in. The concepts are well worth considering in any scheduling practice¹⁰.

This White Paper is part of Mosaic's **Project Knowledge Index** to view and download a wide range of published papers and articles see: http://www.mosaicprojects.com.au/PM-Knowledge_Index.html

For more information on scheduling and planning, visit Mosaic's scheduling home page at: <http://www.mosaicprojects.com.au/Planning.html>

⁸ See **Managing for Success - The power of regular updates**: http://www.mosaicprojects.com.au/Resources_Papers_002.html

⁹ **The VIPER Experience** shows a similar improvement to those claimed by CCPM using traditional CPM scheduling: http://www.mosaicprojects.com.au/Resources_Papers_012.html

¹⁰ For more on scheduling visit Mosaic's **Planning Home Page**: <http://www.mosaicprojects.com.au/Planning.html>

